

The Rocket's Wet Flare!

It Really IS Rocket Science! Part 3

Water Bursting in Air!

Bottle rockets or water rockets, what are they? When someone mentions bottle rockets, do you envision placing a firecracker attached to a stick into a glass bottle and launching it?

Water rockets have been a source of entertainment and education for many years. They are usually made with an empty two-liter plastic soda bottle by adding water and pressurizing it with air for launching (like the image to the right).

Soda companies began using plastic bottles in 1970. The Polyethylene Terephthalate (PET) material used in most plastic soda bottles today was introduced in 1973.

Students will now design model rockets and have an opportunity to match their ingenuity with the limits of Newton's Laws of Physics in order to design their own model rocket that is aerodynamically sound. Students will measure, cut, and glue their rocket parts to the specifications that they themselves determined.

Students should be organized into teams.

Water Rockets - The Parts

Water rockets consist of the following parts:

Nose Cone - an extension of the bottle that comes in a variety of shapes and is used to improve the aerodynamics of the rocket.

Payload section - an optional section that could hold a parachute or a payload.

Body - a 2 liter soda or pop bottle that serves as the propulsion compartment or "engine" of the water rocket.

Nozzle - a part that fits into the bottle opening to help in the propulsion of the rocket and provides a mounting point for launchers.

Fins - a part that helps to stabilize the water rocket.

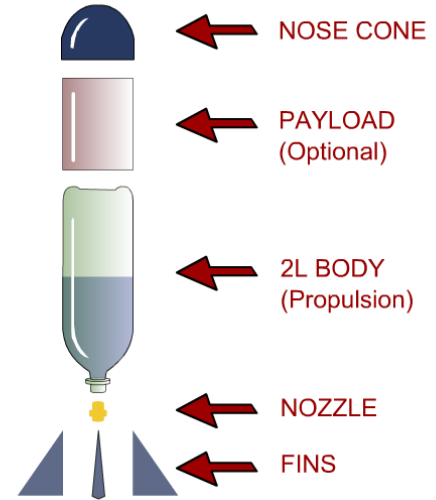

NASA Rocket

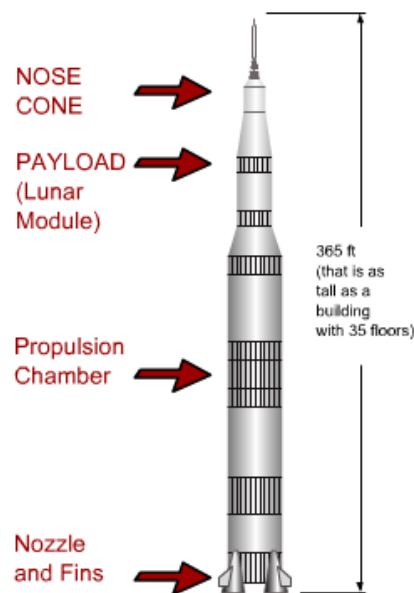

Your Water Rocket

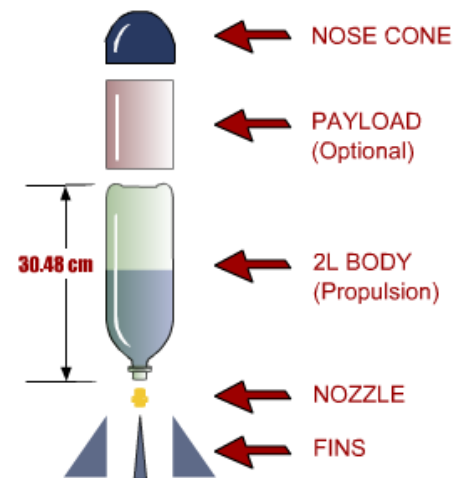

Discuss with them that each group will have many specialized responsibilities for the purpose of launching their rockets and collecting valuable data to be processed and analyzed in the classroom.

Students will practice Pythagorean Theorem as they visualize the giant triangle formed by the flight path of their rocket. Newton's Laws are in full enforcement right before their very eyes. Through the following activities of model rocketry, science and math not only exist, they "come to life."

Basics of the Water Rocket

<http://www.instructables.com/id/Professional-water-rocket-guide/>

Step 1: Let's get started

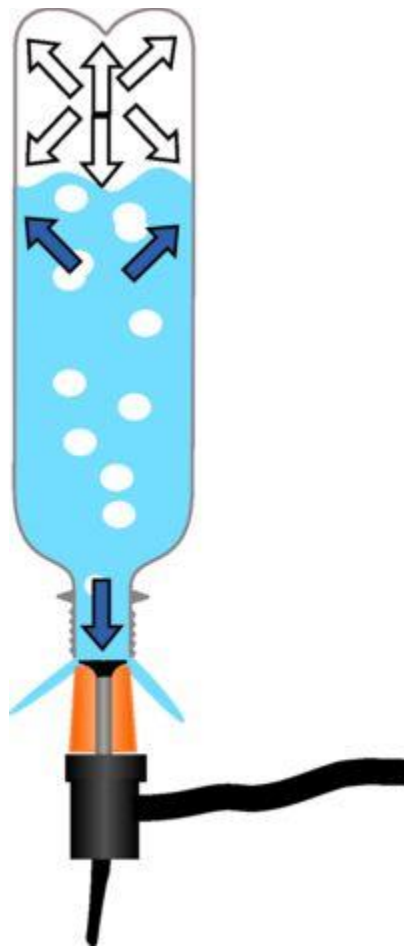

A water rocket is propelled by pressurized air forcing water down through a nozzle. This creates thrust.

If you took a standard two liter fizzy soft drink bottle and pressurized it to 120 psi the rocket would reach about 100 or so feet.

But then if you took 2, two liter bottles and pressurized it to 120 psi again the rocket would go about 150 feet or so because the rocket has more air in it therefore creating more thrust. The rocket will only go 50 feet more because of the added mass. You can stop this by making a two stage rocket. A two stage rocket will work better because it would not have to carry the full payload on all of its flight.

Construction

Almost any 1 or 2 liter bottle will work; however, some bottles have a mouth or opening (nozzle) that

is too small to accommodate the launch tube. The launch tube is a regular 1/2 inch piece of PVC tubing. The tube should slide snugly into the nozzle of the bottle forming a nearly air tight seal. We have found that the majority of Coke™ related 2 liter

bottles and Sam's Choice 1 liter water bottle will work while a majority of Pepsi™ related bottles will not. This is not to say that the smaller nozzle bottles are worthless, rather they should be used for other components of the rocket like the nose cones.



TO GO DEEPER INTO SPACE WE'LL NEED MORE POWER.

ROGER THAT TUCK. LET'S BUILD A SODA BOTTLE ROCKET!

I HAVE ALL THE MATERIALS READY TO GO.

LET'S DO IT!

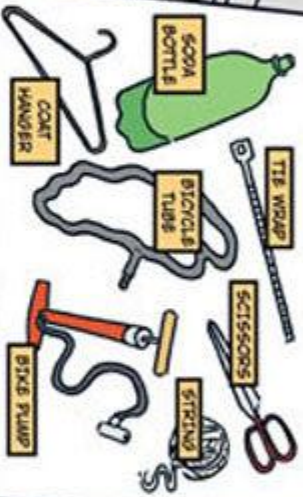

CUT THE VALVE OFF THE TUBE. CUT IT AS LOW AS POSSIBLE.

WITH THE REMAINING TUBE CUT A LONG 1 INCH (2.5 CM) THICK STRIP

WRAP THE STRIP AROUND THE VALVE.

TIE WRAP THE STRIP AROUND THE VALVE. MAKE IT NICE AND TIGHT.

FILL UP THE BOTTLE WITH WATER. COOK UP THE BOTTLE WITH THE WRAPPED VALVE.

TAKE THE COAT HANGER AND CUT AND BEND IT LIKE SO.

TRIGGER MECHANISM HOLDS PRESSURE VALVE TOGETHER WITH RIM OF BOTTLE AS THE AIR IS PUMPED IN. BY YANKING ON THE TRIGGER THE WATER INSIDE IS ABLE TO SPIT OUT THE PRESSURE VALVE AND LAUNCH THE ROCKET.

USE STRING TO YANK OUT TRIGGER.

THERE ARE TWO KEY MEASUREMENTS IN BUILDING YOUR ROCKET LAUNCHER. THEY ARE:

1 THIS IS A KEY WIDTH. SHOULD ALLOW THE TRIGGER TO FIT SNUGLY OVER THE RIM OF THE SODA BOTTLE.

2 THIS IS A KEY DISTANCE. BETWEEN RIM OF BOTTLE AND VALVE TIP SURROUNDED BY ROLLED UP INNER TUBE.

PLACE VALVE THRU LOOP IN HANGER AND CONNECT TO BIKE PUMP.

PLACE ENDS OF HANGER FITFULLY INTO THE GROUND.

WHEN YOU ARE READY TO LAUNCH PUT ON YOUR SAFETY MASK AND STAND AWAY FROM THE LAUNCHER. PUMP TO PRESSURIZE ROCKET THEN PULL OUT THE TRIGGER.

BLAST OFF!

HOW HIGH CAN YOU GO? TRY USING MORE OR LESS WATER.

CHECK OUT THE SOGA BOTTLE ROCKET VIDEO AT MORTONS.COM

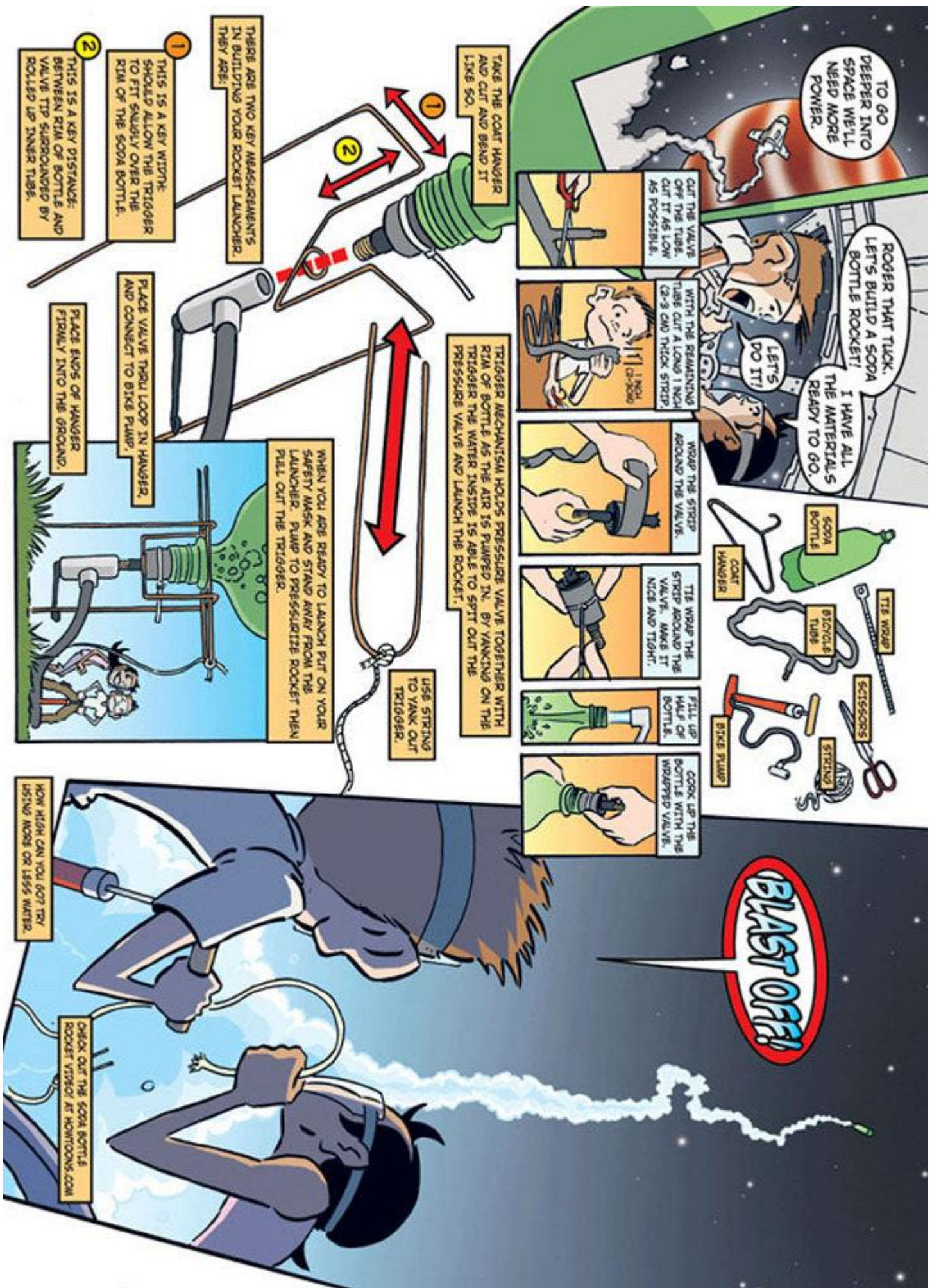

Main Body/Pressure Chamber

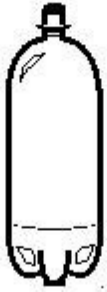

The main part of your rocket is the body or PRESSURE CHAMBER. Peel the label off your bottle and try to clean the glue residue the best that you can. Do NOT use a knife or other object to scrape the label off. Scrape marks can weaken the plastic. Also, do not use hot water the plastic may shrink and weaken the bottle.

Some people have tried to use chemical solvents to remove the glue residue on the bottle. This might alter the walls of the bottle and make them too brittle or soft. Therefore we don't recommend it.

After Cleaning

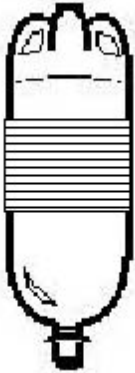

When launching, the pressure inside the bottle will cause the walls to expand. This expansion leads to a loss of energy and will make the rocket fly to a lower altitude. To solve this problem take some or duct tape, strapping tape, or packing tape and pre-wrap three bands around the pressure chamber. You don't want the tape to be too bulky and watch for wrinkles. This will strengthen the walls of the bottle without adding too much mass and launch altitude will increase overall.

How to build a fins and nose cones



In the next few steps you will be shown how to build the basic needs of a bottle rocket. This step is to get to grips on what a rocket needs.

Nose cone

Nose cones are not only for performance but add character and style to your rocket. Be sure to



take some time thinking out the design of your rocket before committing to a plan of action. Shown here are only one or two examples; so don't be afraid to be creative.

"Bertha Series" Ping Pong Popper Method

Step 1: Cut the top and bottom off a 1.25 liter bottle. Then cut the neck off the top.



Step 2:

Cut a ping pong ball in half with a craft knife, Then glue half of the ping pong ball into the top of the 1.25 liter bottle 'top'.

Use a plastic adhesive glue, or if appearance doesn't matter you could just tape it on!

Step 3:

You will glue or tape the nose cone to the top of the 2 liter body of your rocket.

Note: Adding weight to the nose cone may help, it will move the center of gravity higher, making the rocket more stable.

"Bertha Series: Nose-cone Variation B

Once again, this will be made by cutting the bottom off a **spare bottle** with a pair of scissors and attaching the top portion onto the pressure chamber. **(Note: Never cut the pressure chamber)** To mark a straight line around the bottle for cutting, place the bottle in a short can and hold a marker on the lip of the can as you rotate the bottle. Before attaching the nose cone, add a small lump of Play-Doh or clay in the bottle's neck to increase the mass. After the Play-Doh is pushed in place tape over it with some duct tape and replace the cap.



Once they launch the rocket see how it hits the ground they will understand the reason for the tape. Make sure you have a cap on the nose cone. Before you tape the cone on, roll the rocket over a flat



surface to make sure the cone and pressure chamber align. A curvy rocket will not be safe coming off the launcher.

Fins

Fins are the guidance system for your rocket. Without them a rocket would tumble end over end. Fins can give your rocket life and beauty. Fins can portray aggressive power or aerodynamic grace.

However, fins tend to be the single greatest downfall of many young rocket builders. With the incredible speeds and acceleration generated at launch, many fins get ripped off the rocket body within a fraction of a second.

Fins should be firm; if they flop around they are useless.

Fins should be adequately secured; duct tape works well. Do not use glue because it does not expand with the pressure chamber and may cause it to become brittle.

The best fins are made of rigid cardboard or Styrofoam board.

The size of the fin does matter! The best rockets fly well with long and narrow fins. Find out for yourselves what works best for your rockets through experimentation.

Straw-Rocket Aeronautics

NASA/JPL straw rockets. Activity description courtesy: John Callas, NASA/JPL

To help students get a better idea of balance learn and learn about fins roles in rocket stability have them construct and fly small “indoor” paper rockets, then analyze flight data and interpret the results to apply what they learn to their large rockets.

Materials Per student or team:

- [Rocket template & data analysis worksheet \(.pdf\)](#)
- Pencil
- Scissors
- Tape
- Drinking straw

Who doesn't love rockets? Or blowing through a soda straw? In this experiment, students get a hands-on feel for rocket stability and aerodynamics by constructing and flying small paper rockets propelled by air blown through a straw. The goal is for students to conduct an experiment, analyze the data, and interpret the results. Also to have fun!





JPL's Jojo Aguilar shows how to make the rocket: Cut out the template, wrap the long rectangular section around a pencil, tape the fins, insert a straw and blow! *Image credit: NASA/JPL*

1. Download and print the soda-straw rocket template, at least one per student or group, from: <http://www.jpl.nasa.gov/education/images/pdf/sodastrawrocket.pdf>
2. Carefully cut out the pieces and assemble the rockets according to the following instructions. Once completed, you will have a nice little rocket that stands just over 5 inches tall.
 - Carefully cut out the rectangle. This will be the body tube of the rocket. Wrap the rectangle around a pencil length-wise and tape the rectangle so that it forms a tube.
 - Carefully cut out the two fin units. Align the rectangle that extends between the two fins with the end of your body tube and tape it to the body tube. Nothing should stick out past the body tube! Do the same thing for the other fin unit, but tape it on the other side of the pencil, so you have a "fin sandwich."
 - Bend the one fin on each fin unit 90 degrees so that each fin is at a right angle to its neighbor. When you look along the back of the rocket, the fins should form a "+" mark.
 - Using the sharpened end of your pencil, twist the top of the body tube into a nose cone. Measure your nose cone from its base to its tip and record the length on your Data Log and on the rocket itself
 - For the Data Log, create a chart on a piece of paper with columns labeled "Rocket Length" and "Distance Traveled." For every attempt, fill in the log.
3. Remove the pencil and replace it with a soda straw.

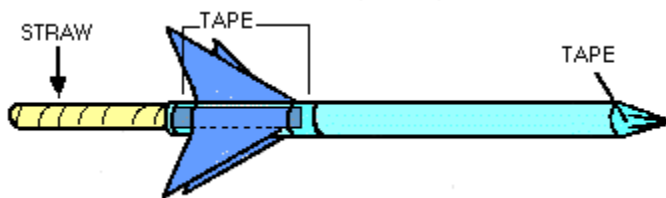

4. Record the rocket's length on your Data Log.
5. Blow into the straw to launch your rocket! Record the distance it travels on your Data Log.



6. Next, make rockets of different lengths to see how that affects the results. (*Vary the length by cutting the tube that forms the rocket.*)

Extensions

- When students are finished recording data, see if they can use their findings to reach objects, such as a classroom globe.
- Students should work in groups of four to six and build rockets of different sizes. They can share data and discuss how rocket length affects distance.
- Let students personalize their rockets by coloring or drawing on them.
- Students can experiment and improve on their current design or design entirely new rockets for better space travel.



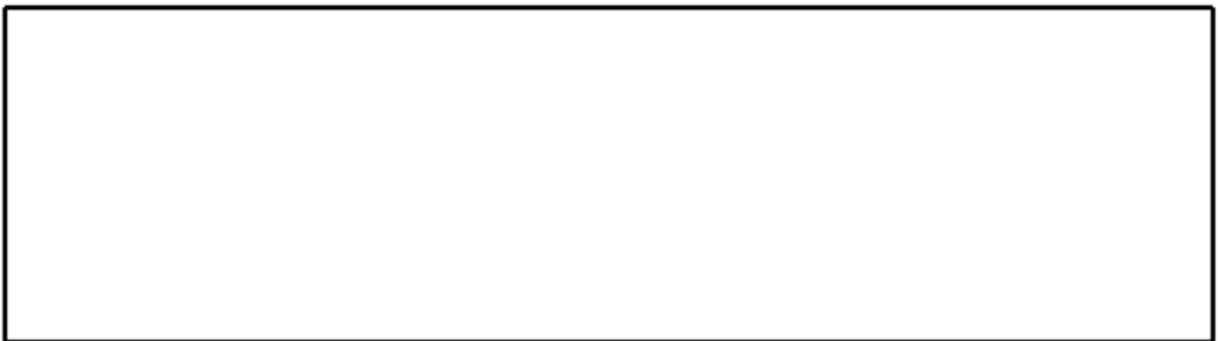
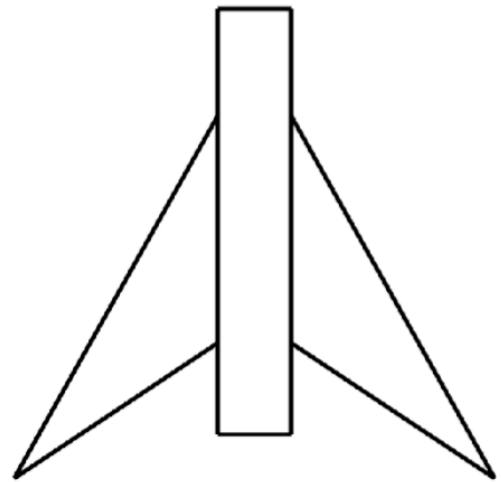
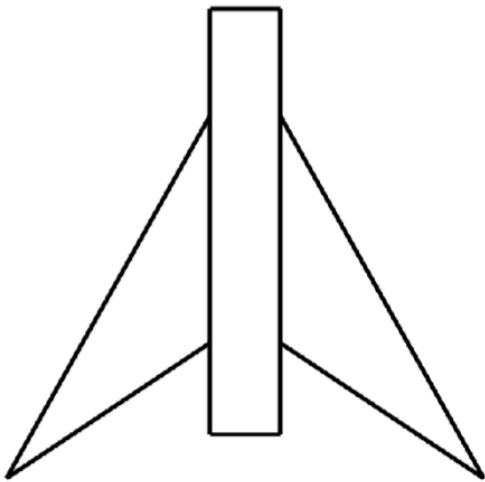
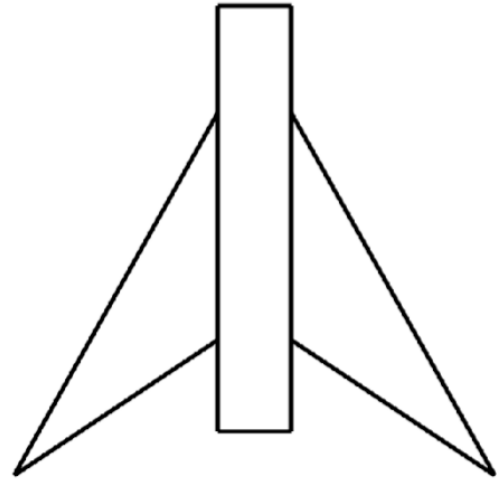
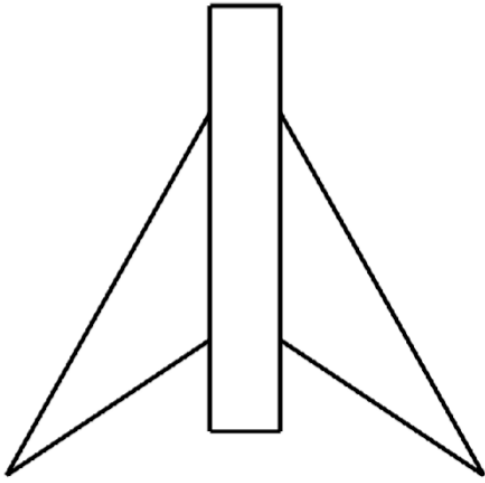

Soda-Straw Rocket Data Log

Distance Traveled (in cm)

Length of Nose Cone	Trial #1	Trial #2	Trial #3	Trial #4	Trial #5	Notes
Control						

Soda-Straw Rocket Data Analysis

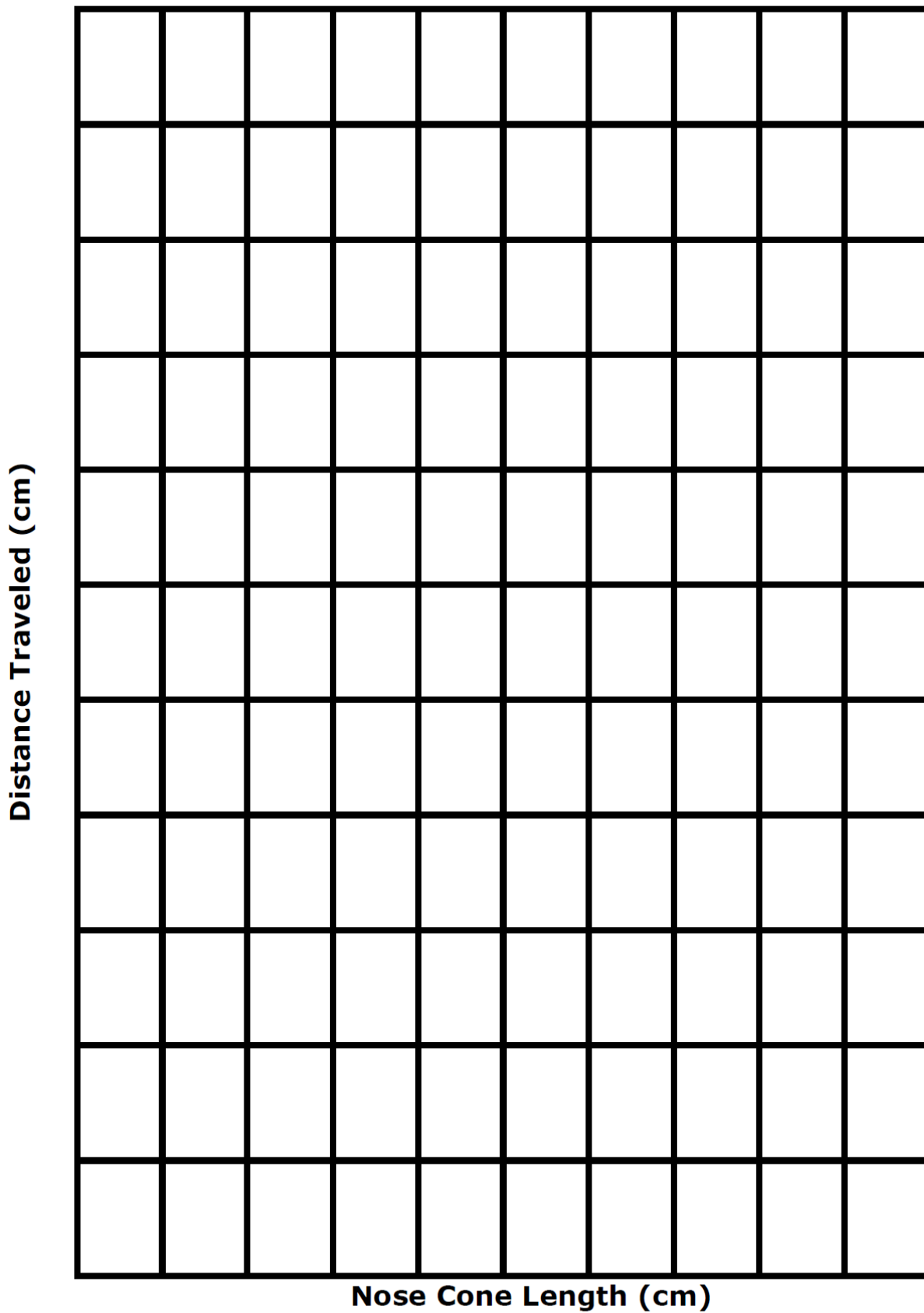

Now, have students apply what they learned to construct fins for their water bottle rockets!

Materials: (remember lightweight but sturdy)

- Paper clips or Index Cards
- Duct Tape or Clear packing tape
- Cardboard (cheap, plentiful, soggy when wet)
- Chipboard (cereal boxes)
- Foam core (a little tougher but more \$, some water damage)
- Sturdi-board (like plastic cardboard, great stuff, \$\$, no water damage)
- Balsa wood (might be a little heavy, fragile on impact)
- Styrofoam sheets* (cheap, low mass, fragile on impact)
- *Requires PL Premium Construction adhesive to attach

How many fins do I need?

To ensure stability and safety, the minimum number of fins on a rocket is three (3). Many people choose a 3 or 4 fin design. There is no maximum number of fins you may have but keep in mind that the more fins you have the more drag you will create and drag slows a rocket down.

BASIC FIN DESIGNS

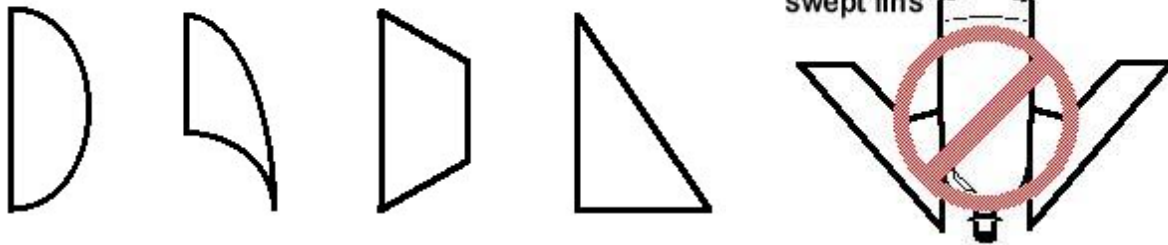

Constructing fins

1. Be creative and cut out 3 or 4 identical fins. You can use any shape except "forward swept" fins.
2. Lay the fin on a flat surface.
3. Use a paper clip bent at 90 degrees and taped it to the fin or an index card taped onto the side of the fin. Be sure to leave a one-inch tab on the index card. You will later bend this tab out 90 degrees to make an attachable area for the rocket.
4. Repeat the same for the other side of the fin.
5. Repeat with other fins.

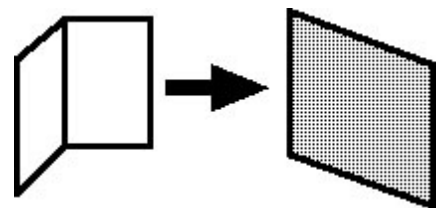

You should now have 3 or 4 fins each with either paper clips or two-index card tabs attached to the fins. (If you use cardboard laminate the entire fin surface with tape to reduce the amount of water damage to the fins.)

Fin placement

The fins of your rocket can't be placed above the halfway point of your pressure cylinder. You want to place your fins at the base of the rocket to lower or maintain the center of gravity. If you were to place the fins above the center of gravity, the rocket would tumble and spin out of control once it left the launch pad.

Attaching the fins

This is the tricky part. Gluing the fins on is **not** recommended including hot glue and "Liquid Nails" type adhesives are not flexible enough when it comes to the launch.

The bottle pressure chamber might expand a millimeter or more in circumference when it is pressurized. That is enough to break the bonding seal of most glue. When the rocket is launched, the fins usually rip off. Tape usually works the best at holding the fins on the rocket due to its flexibility.

1. To find the location of the fins on the bottle, take a piece of string and wrap it around the outside of the bottle and mark the length using an ink pen. Remove the string from the bottle and lay it out in a straight line and mark the string in 3 or 4 equal lengths depending on the number of fins you are going to use. Wrap the string around the bottle again and transfer the marks to the bottle. If you are using 4 fins this will create 90-degree angles, 3 fins will be at 120-degree angles. To mark a straight line on the bottle, lay it in a door jam and use the straight edge to draw a line the length of your fin. You now have the locations of where to attach your fins.

2. Apply a piece of tape to the paper clip or index card tabs and carefully tape them to your rocket.

3. Look at your fin. Make sure it doesn't curve or it isn't crooked. It should be in a direct line with the body of your rocket. If it isn't perfect, take it off and try again.

3. Attach the other fins. Test the wiggle of the fins. Your fins shouldn't wiggle more than a few centimeters from side to side. Adding more tape to the top and bottom areas of the fin might fix this problem.

How does it all work?

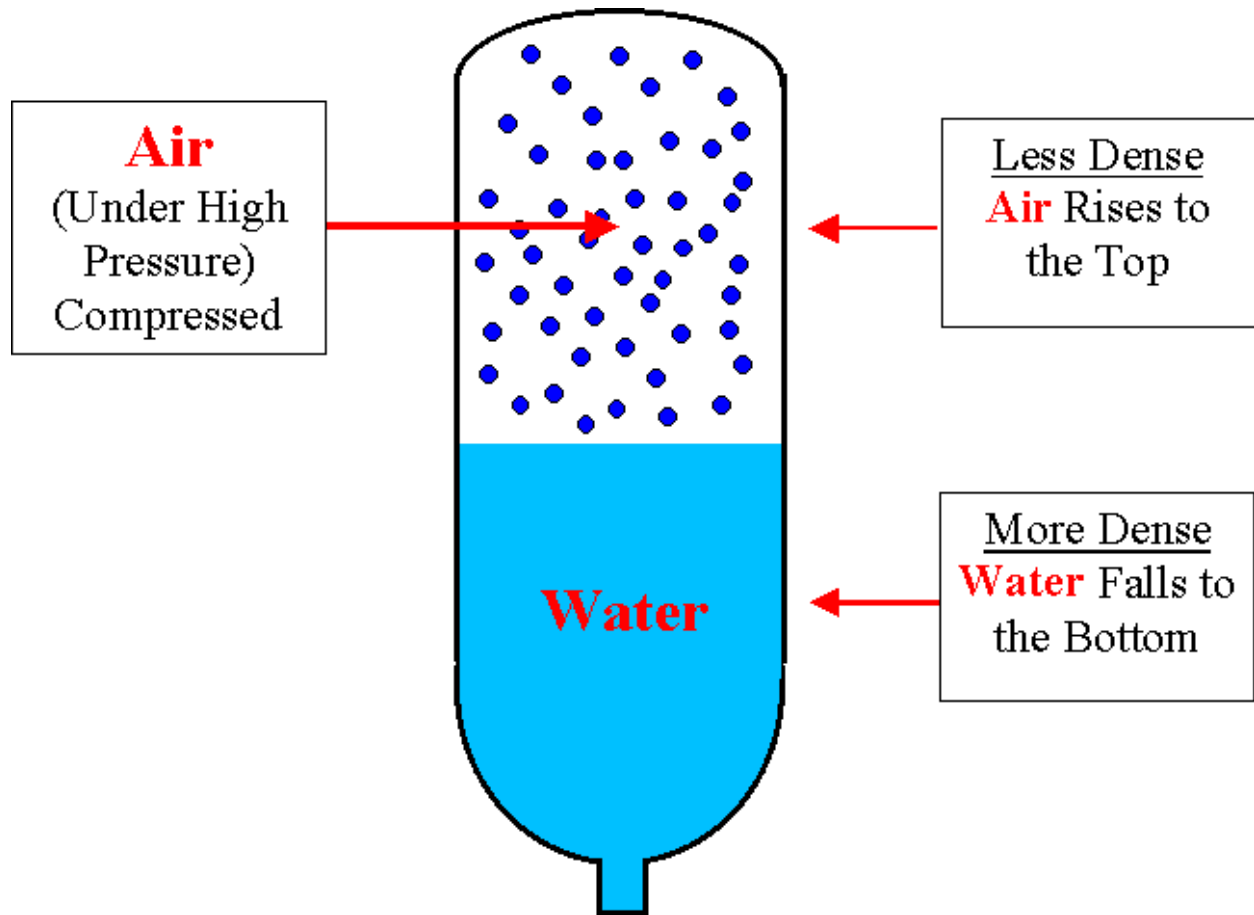

Air enters the pressurized vessel from the bottom and presses down on the water. When the pressure reaches a critical level, it pops the "cork" out of the nozzle and the pressurized air expels the water from the nozzle.

Air is a mixture of gases that can be compressed. As more and more air is forced into the rocket "engine," air molecules are packed more and more tightly together. Pressure inside the container is very high. When the stopper is released, the compressed air in the container rushes out.

Shift Center of Mass Up!

By placing a clay ball or weight in the nose cone the Center of Mass is moved high enough on the rocket so that it won't tumble on lift off. Rather like an arrow is heavier up front than it is in the middle or back, which helps it fly straight.

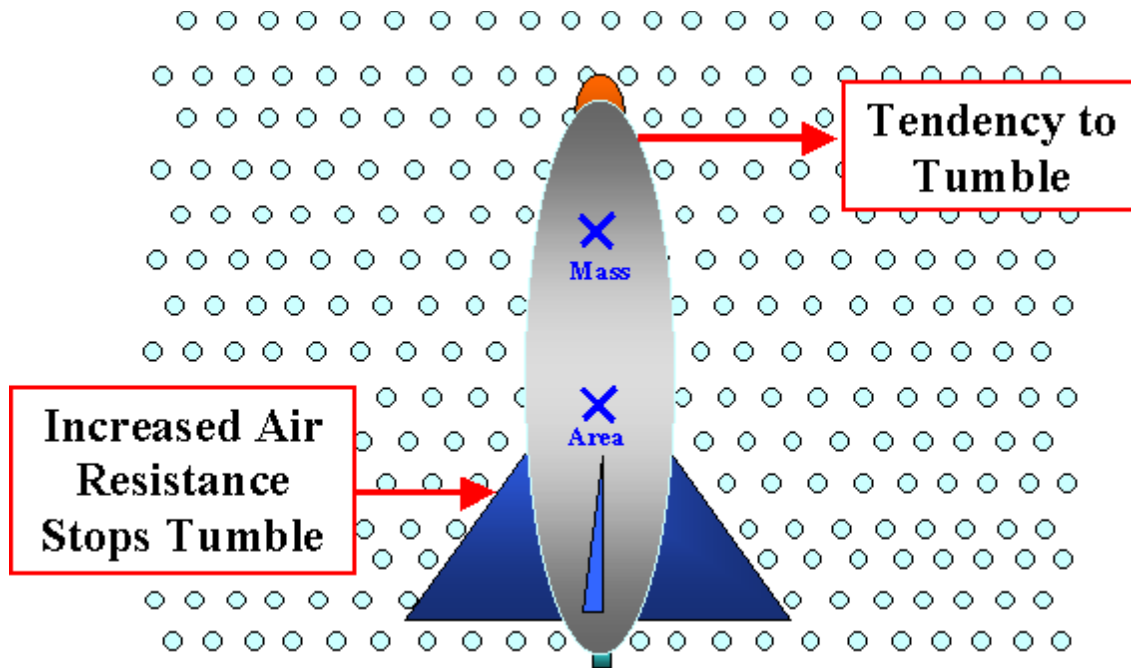

If the center of mass of your rocket is too close to the center of area, your rocket will cartwheel out of control. It will NOT fly straight! Moving the center of mass UP away from the midpoint of the rocket, will help to ensure that the rocket flies straight.

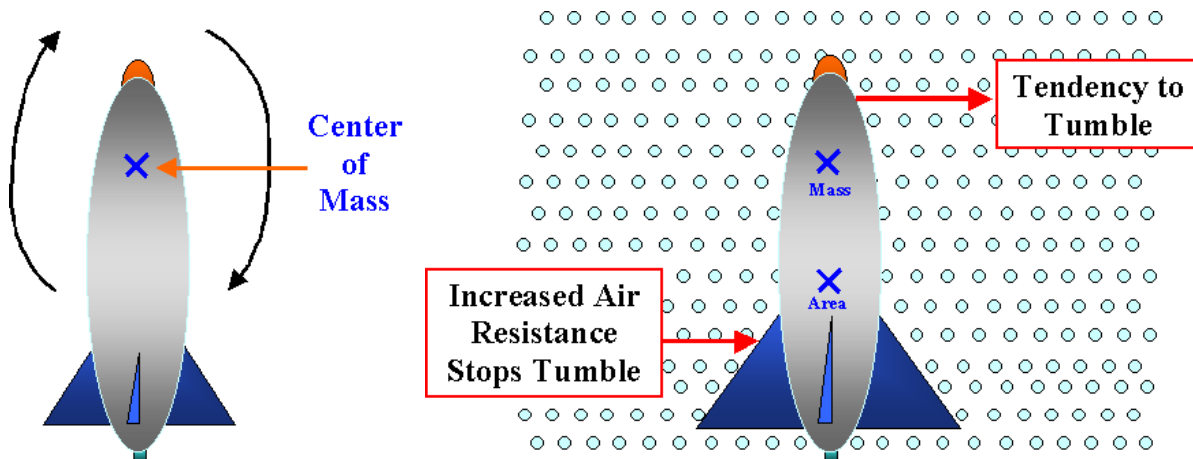

Here is a way to tell if your rocket will tumble. Measure the Center of Mass & mark this spot on your rocket. Now measure the Center of Area (the geometric center of an object's shape) and mark this space as well. If the two marks are further apart than the width of your rocket body, you are probably in good shape.

The best way to determine Center of Mass is to balance your rocket on a yardstick, like the balancing of a seesaw.

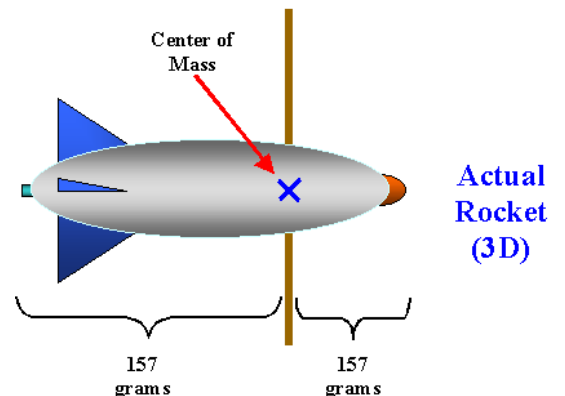

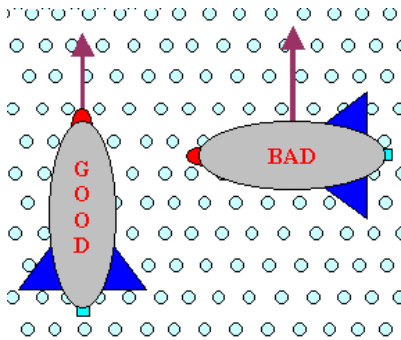

Obviously, if your rocket behaves more like the one on the left it is more likely to fly straight. The rocket on the right will tumble out of control.

Newton's Laws

We can use the water Bottle Rocket to study and see Newton's Three Laws in action

Preliminary Questions to consider:

- Why do bottle rockets fly?
- Why do we have to use water, or do we?
- Will it fly without water?
- If a little water works well, will a lot of water work better?
- Will it fly best when it is totally full?
- What volume of water works best?

These questions can be answered by demonstration using a bottle with no modifications and with various levels of water. As with all good demonstrations more questions usually arise, such as:

1. Why did the rocket that was full of water barely take off?
It was too heavy or massive. This can be explained with Newton's first law of motion; A body at rest tends to remain at rest and a body in motion tends to stay in motion.
2. The rocket didn't have enough "oomph" (force) to make it take off. Why?
There was not enough force for the relatively huge mass. The more mass it has, the less it will accelerate using the same force. This can be explained using Newton's second law of motion: Force equals Mass times Acceleration.
3. Why did the water go one way and the rocket the other?
There is an equal force in both directions. This can be explained by Newton's third law of motion: For every action there is an equal but opposite reaction.

To help students get a feel for Newton's Third Law you need a heavy ball (medicine ball) and a skateboard or skates.

- 1 Have a student stand on the skateboard (with a spotter on each side) facing the front and hold the medicine ball at chest level.
- 2 They will throw the ball horizontally to another person without bending their legs or pushing the skateboard. Describe what happens.
In what way is this similar to the rocket?
Which is the action force and which is the reaction force?
- 3 Find out what happens when you throw the ball harder. Track and interpret your results.

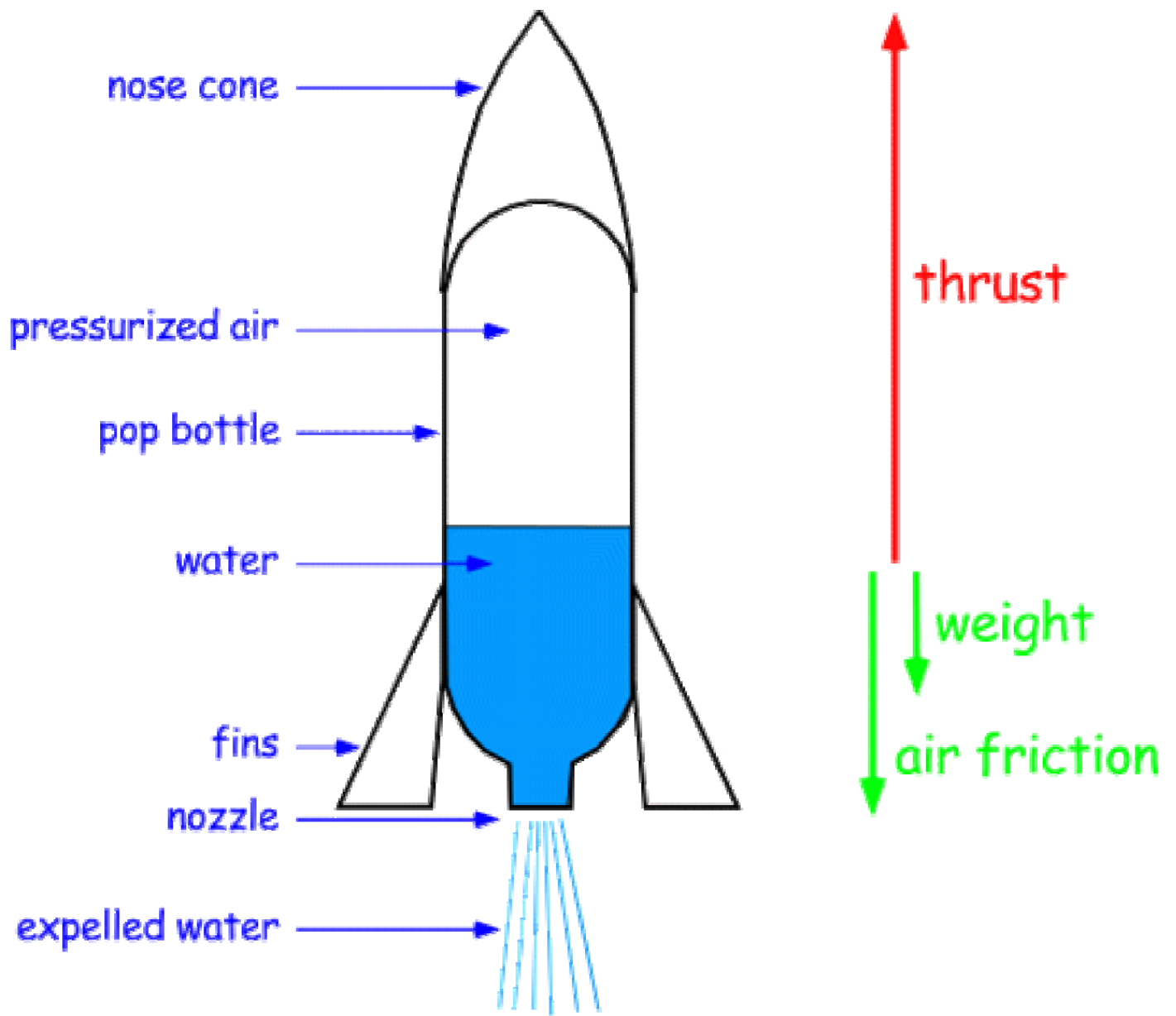

Measuring the altitude of the bottle rocket

“Whoa! How high did that thing go?” has probably been a question you’ve asked several times as you watched your rocket soar overhead. There is a relatively simple method student can use to measure the altitude of their rocket! It is simply a sheet of graph paper mounted on a sheet of cardboard with a plumb line attached to one corner.

Have students write a hypothesis stating how they think changes in the volume of water in the rocket’s fuel will affect the rocket’s apogee. Apogee is the highest point of the rocket’s flight.

Figure 1: Assembling the Altimeter from Arbor Science

http://www.arborsci.com/CoolStuff/New_CoolStuff_Articles/Downloads/P4-2050.pdf

©2011 ARBOR SCIENTIFIC ALL RIGHTS RESERVED

To assemble the altimeter, paste the altimeter face page to a flat sheet of cardboard that has been cut to the same size. Make sure the top edge of the cardboard is flush with the top edge of the altimeter page. Use a common pin to poke a hole through the cardboard at the top front corner where indicated. Slip one end of the plumb line (thread) through this hole.

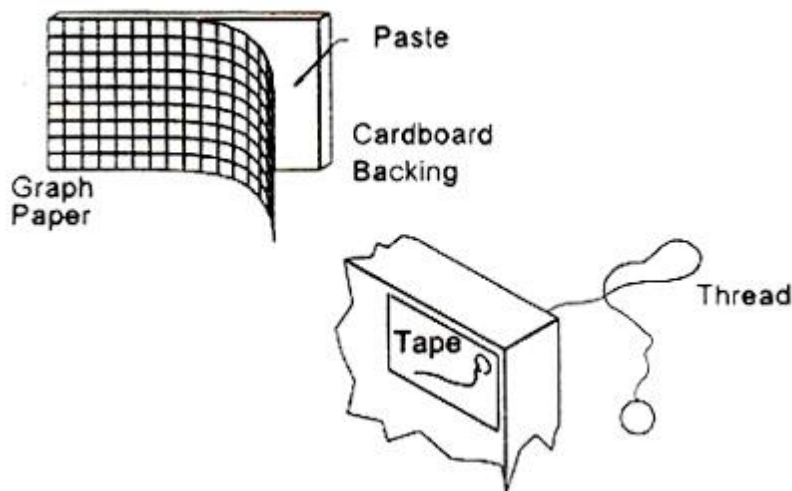

Figure 2: Reading the Altimeter

Tape the thread to the cardboard backing where it comes through the hole. Tie weight (large washer) to the free end of the thread as in Figure 1.

Their altimeter is now ready to use!

Let’s start by measuring the height of something we know. First, measure the distance between the object you’re measuring and the position you will be standing when you measure its height.

This distance is called the “BASE” and should be at least 10 meters.

Hold the altimeter card at eye level and sight along its top edge. Some find it easier to tape or glue a fat soda straw along the top edge as a sighting tube. The place where the thread is taped to the cardboard should be away from you.

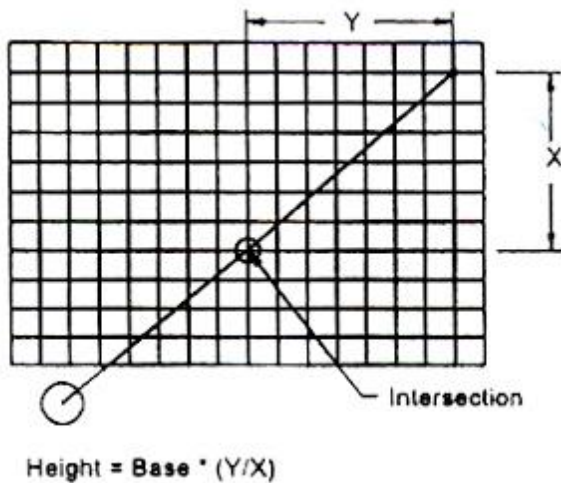

Tip the cardboard upward until the top edge of the cardboard is pointing at the top of the object you're measuring. When the string is hanging freely and no longer swinging, pinch it against the face of the altimeter with your finger, as in Figure 2. You can now read the altimeter by finding an intersection on the graph paper that the string crosses. Read the quantity "Y" from the horizontal axis of the graph paper (this is proportional to the height of the object) and read the quantity "X" from the vertical axis of the graph paper (this is proportional to the distance between you and the object). Using similar triangles, the rocket altitude or "HEIGHT" can be calculated by using the following formula:

$$\text{HEIGHT} = \text{BASE} * (Y/X)$$

Where: HEIGHT = height of the object

BASE = horizontal distance from the object

Y = measured from the altimeter (horizontally)

X = measured from the altimeter (vertically)

Don't forget to add your own height to the calculated height! Actually, you should measure the distance from the string hole down to the ground, and add that to your calculated height. Your most accurate measurements of height, using this device, will be found when your horizontal distance from the object, in value, is close to the actual altitude of the object.

The altitude of the object will have the same units as does the horizontal distance from the object. In other words, if you measured the distance from the launch pad in meters, then your calculations will produce an altitude in meters. If you measured the distance from the launch pad in feet, then the altitude will be in feet.

Now that students are able to get accurate measurements of the rocket's altitude, they're ready to do some serious experimenting! Remember – change only one thing at a time; keep everything else constant!

For example, to measure the effect of pressure on the rocket's altitude, use the same rocket, pour the same amount of water into the bottle, and then, for each experiment, pressurize the bottle to different amounts. Record each launch on a data sheet that might look like Table 1.

Table 1.

Rocket Launch Data:					
Launch #	Water Used <i>oz or arams</i>	Rocket Weight <i>lbs or kiloarams</i>	Pressure Used <i>PSI or kPa</i>	Altitude <i>Feet or meters</i>	Flight Time <i>In seconds</i>
1					
2					
3					
4					
5					

Conclusions should be supported by data. Discuss with students that extreme values in a data set are known as outliers. Any outliers should be explained in the conclusion.

Y

1 2 3 4 5 6 7 8 9 10 11 12 13 14 15

X

1 2 3 4 5 6 7 8 9 10 11 12 13 14 15

- 1 - Sight rocket along top edge of altimeter.
- 2 - When rocket is at peak altitude, pinch the plumb line against the graph paper.
- 3 - Look along the plumb line for a convenient intersection.
- 4 - Determine X and Y from this intersection.

Punch hole for string here

$$\text{Height} = \text{Base} * (Y/X)$$

Glue this sheet onto a backing of cardboard.

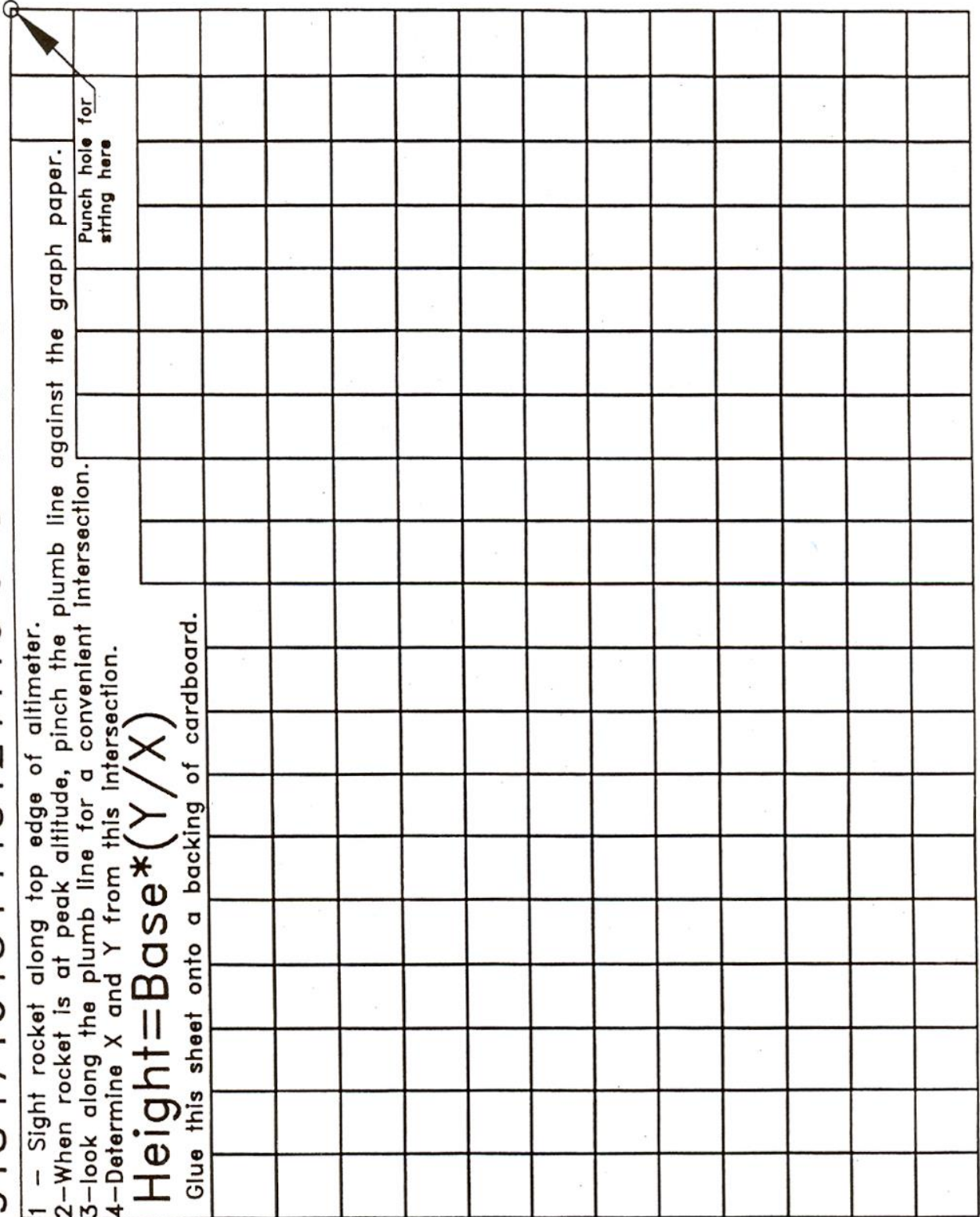

-Rocket Altimeter-

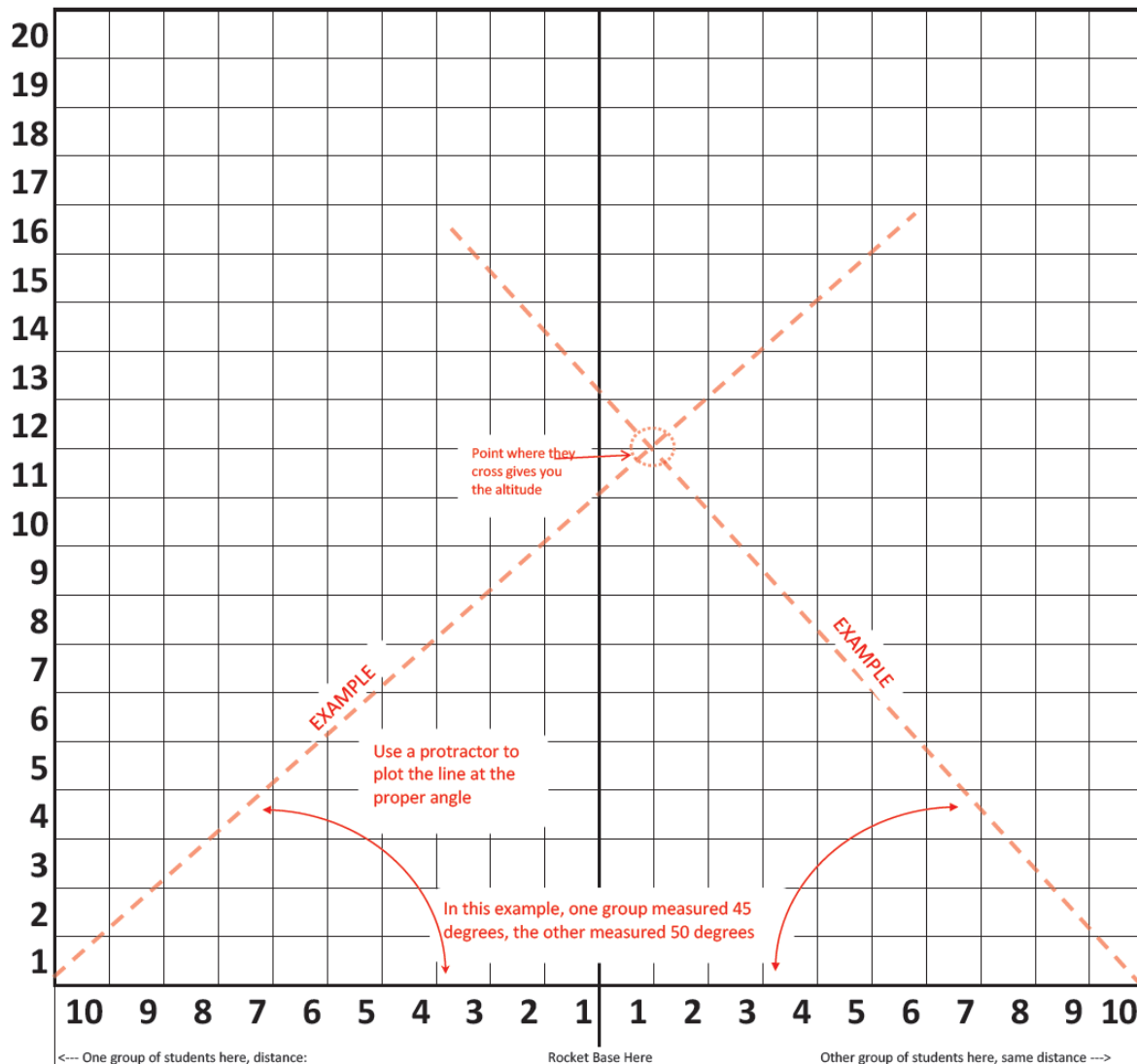

Tip: Use a protractor to plot the angles.

This chart is 20 units X 20 units, so because the rocket base is represented by the middle, each student group will be 10 units away from the base. Divide the distance you students are standing from the base by the 10 units on this cart. So for example, if your students measured from 30 meters, then each unit would be 3 meters (i.e. 30m / 10 units). Using the angle for each student group, you draw a line from each end of the x-axis and note where they cross. This crossing point indicates the altitude of the bottle. Again, if each unit is 3m, and the lines crossed at unit 12, then the altitude is 36m. What is a good distance from the base? This depends on the heights you intend to reach. With the bottle rocket launcher, you will likely be safe using 20-30m. For higher flying rockets, like CO2 rockets, you'll need more distance. Note that this method requires no trigonometry or altitude calculations.

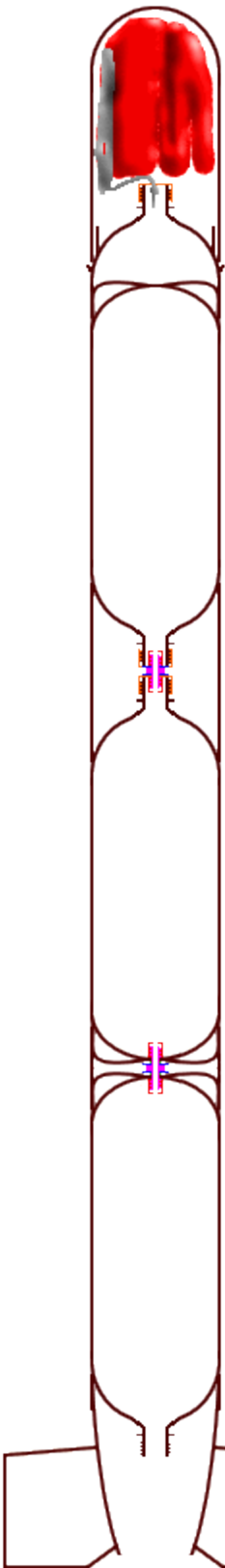

- Rocket body parts
- Plastic bottle caps
- Brass nuts
- Brass Fittings
- Rubber O-rings
- Washers

Advanced Design Water Bottle Rockets

The follow are some advance designs students can make with their rocket and require a bit more work but are incredibly fun to build. Did you know? The world record for highest altitude for a water rocket is almost 2,000 feet.

Professional water rockets can vary from big one stage rockets to 2 stage rockets with drop away boosters.

Step 1: coupling and splicing

How to couple bottles

First drill a hole about 7-8mm in width in the bottom of one of your bottles.

Next screw the male end of a plumbing coupling which is about 8mm in width into the bottom of the bottle, then seal it with a sealant glue. Next drill an 8mm hole in the other bottle cap and then insert the male end in to it. Whist the bottle cap is off the bottle, screw the female end into the other side of the bottle cap (side facing the inside) if you want you can seal it with glue as well.

How to splice

To join two bottles together like in the picture to create an air tight seal you need three bottles. First cut the bottom ends off two of the same sized bottles. Then, cut both ends of the same sized third bottle and place that in the two exposed ends of the bottle. Next, glue the third bottle in the 2 exposed ends.



Parachute Systems

By now students may have spent a bit of time building the rocket of their dreams. It may not be completely obvious to your students yet, but as the old saying goes, what goes up... must come down. It's time to think about saving all that precious work by creating a recovery system for their rocket. Here are a few ideas to get you started. Fins have been removed for clarity. (Note: you may substitute "crepe paper streamers" for "parachute" in most of the following examples)

Here is a list of materials:

- Tall kitchen garbage bag -or- Kite string or Yarn
- Four-grocery plastic bags
- Baby Powder
- Scotch Tape
- Hole punch

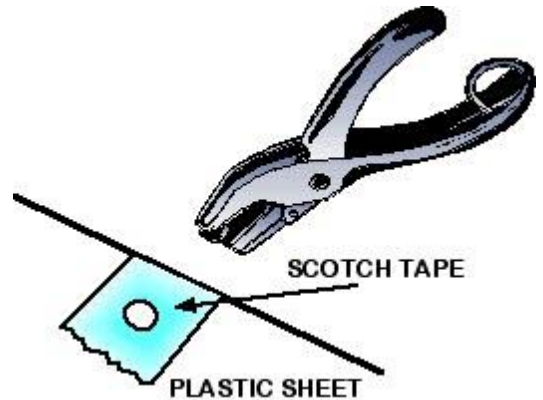

The size and shape of their parachute can be as varied as their rocket. A good rule of thumb is to make their chute 6 to 12 inches across depending on a 1 or 2 liter bottle. Their chute could be larger but some rocket styles have narrow nosecones and the chute could get stuck.

Making the Chute

Carefully cut the garbage bag along one side and the bottom seam. Open the bag along the fold and lay it flat. If you want to use the grocery bags, cut each bag in the same way but lay them out side by side 2 X 2. Use some scotch tape and tape the center seams to make a larger surface area.

The Square Chute

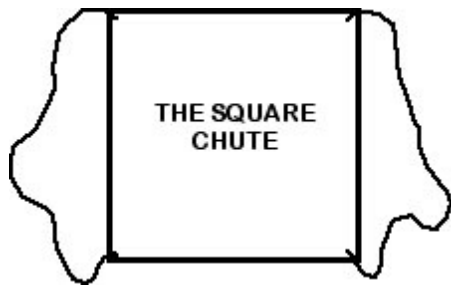

The simplest chute to make is the "Square Chute". Prepare the edges, where you will connect the strings, with scotch tape grommets. First apply a piece of tape to both sides of the plastic.

Then, with a hole punch, punch a clean hole through the center of the tape and plastic tab. Repeat this procedure for each location where you are placing a string.

To complete the "Square Chute", measure two 24-inch lengths of string and tie each end to one of the grommet holes. Bring the centers of the string loops together and tie them off.

The Circle Chute

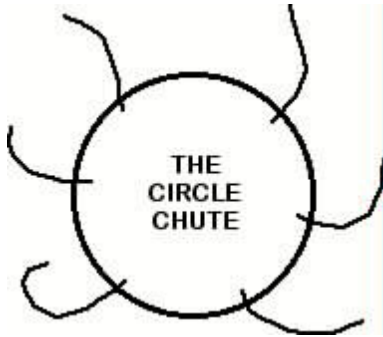

The "Circle Chute" is a classic, timeless engineering masterpiece. If you have a large tire or similar round object you can trace the circle on the plastic with a marker and cut. If you don't have anything large enough to trace, fold the plastic in half, then in half again, then fold on the diagonal. This will give you a triangular wedge. With a sharp pair of scissors, cut along the section that has the open edges. You don't have to worry about cutting on the curve, just cut straight across the bottom. If you want students to practice this first, have them try cutting a piece of paper first. Finish the edges with tape grommets as mentioned above. Lastly, tie separate 24 to 36 inch string leads to each grommet. Gather the leads together and finish the strings off with a good knot.

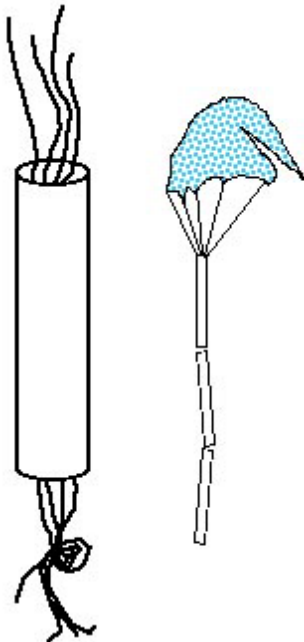

Anti-Tangle Armature

One of the unforeseeable happenings in rocket parachuting is getting the strings caught or tangled in the fins or safety lines of the rocket. An easy way to avoid this problem is to build this simple cable shield for your chute. Cut two or three straws into 4 or 6-inch sections. Slip the extra long string leads, from your parachute, into the straw sections. The armature should protect the strings as the chute deploys and then slide down out of the way when your chute opens up. (Note the illustration is NOT to scale.)

Folding the Chute

Dust the chute with baby powder to ensure that it doesn't stick to the side of the rocket or itself. Grab the chute between two fingers, in the center, and pull it up toward the ceiling. Let the chute fold naturally as you lift it. Once you have the chute pulled up, fold it once in half at the center. You don't want to fold the chute too tightly

but you can fold your chute into thirds if space is a factor. Wrap the excess string loosely around the chute. Fold the straw armature sections onto the chute but not part of the excess string wrap.

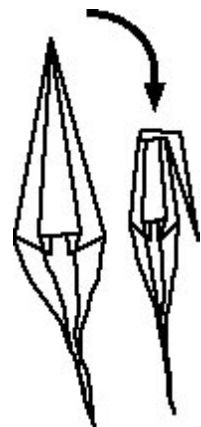

Making a Sleeve

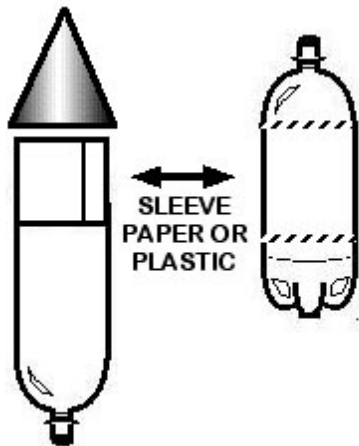

If you find that the chute area is too small to hold your parachute, you can increase the size of container by adding a section of chipboard around the girth of the bottle. Or you can use another 2-liter bottle.

Remove the top and bottom of the 2nd 2-liter and tape the new cylinder into position. This tends to make your rocket more stable by increasing the distance between the Center of Pressure and the Center of Gravity.

The "Bertha Cone Chute" (3 out of 5 Stars)

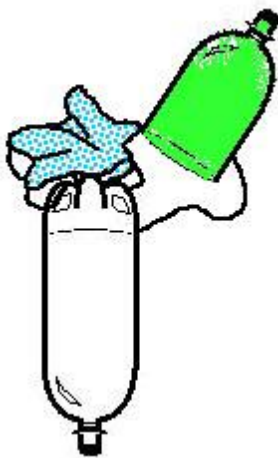

With this chute system, instead of taping the nose cone on, attach a safety cord to the weighted cone and apply a parachute to the top of the pressure cylinder. In theory, once the rocket reaches apogee (the highest point of travel), the weighted nose cone separates from the main body. The main body is creating enough drag to slow itself down. If everything works, the parachute deploys and the two pieces float gently back down to earth.

In practice, the nose cone can sometimes get jammed on the main body causing a failure. In addition, safety cord can be too short and the cone can't clear the body.



Nose Cone Tug Chute (3 out of 5 Stars)

The "Tug Chute" uses the force of the lifting nose cone to pull the chute out of the sleeve or needle assembly. Attach a safety line to the nose cone or tennis ball. Attach a parachute close to the cone/ball assembly. The chute needs to be folded small enough to fit inside the needle yet not too tight to unravel.

Problems with this system include; not enough line and parachute packing jams. Cone style noses with a sleeve have more success with this system.

The "Space Needle" style of nose cone can be made from a spare bottle, empty paper towel roll, and a tennis ball or racket ball. This type of nose cone adds a great deal of inertial mass to the rocket and makes it really stable. Simply, attach the towel roll to the top of a single Bertha nose cone and then fix the tennis ball to

the top of the roll. Take your time building this set up because you want the entire assembly to be straight as an arrow.

Cut tabs in an index card and glue or tape the card to the tube. This will hold the tube upright. Then tape the tabs onto the nose cone top.

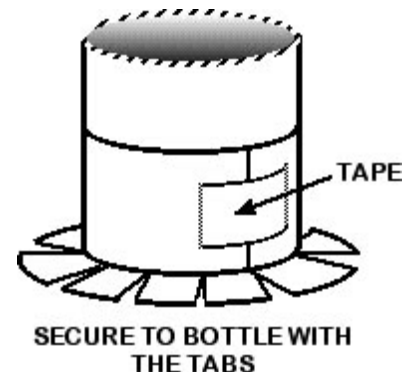

Launchers

Students construct a bottle launcher from "off-the-shelf"

hardware and wood using simple tools. This launcher, designed by NASA, can hold any type of pressure depending on the rubber bung.

If you have a different nozzle size then you can adjust the nuts on the bolts so the pins can line up with the hole in the 90 degree mending plate and the neck of the bottle.



Materials and Tools:

- 4 5-inch corner irons with 12 3/4 inch wood
- screws to fit
- 1 5-inch mounting plate
- 2 6-inch spikes
- 2 10-inch spikes or metal tent stakes
- 2 5-inch by 1/4 inch carriage bolts with six 1/4 inch nuts
- 1 3-inch eyebolt with two nuts and washers
- 4 3/4-inch diameter washers to fit bolts
- 1 Number 3 rubber stopper with a single hole
- 1 Snap-in Tubeless Tire Valve (small 0.453 inch hole, 2 inch long)
- Wood board 12 by 18 by 3/4 inches
- 1 2-liter plastic bottle
- Electric drill and bits including a 3/8 inch bit
- Screw driver
- Pliers or open-end wrench to fit nuts
- Vice
- 12 feet of 1/4 inch cord
- Pencil

Note: If you have each student construct a bottle rocket, having more than one launcher may be advisable. Because the rockets are projectiles, safely using more than one launcher will require careful planning and possibly additional supervision. Please refer to the launch safety instructions.

Consult the materials and tools list to determine what you will need to construct a single bottle rocket launcher. The launcher is simple and inexpensive to construct.

Most needed parts are available from hardware stores. In addition you will need a tire valve from an auto parts store and a rubber bottle stopper. The most difficult task is to drill a 3/8 inch hole in the mending plate called for in the materials list.

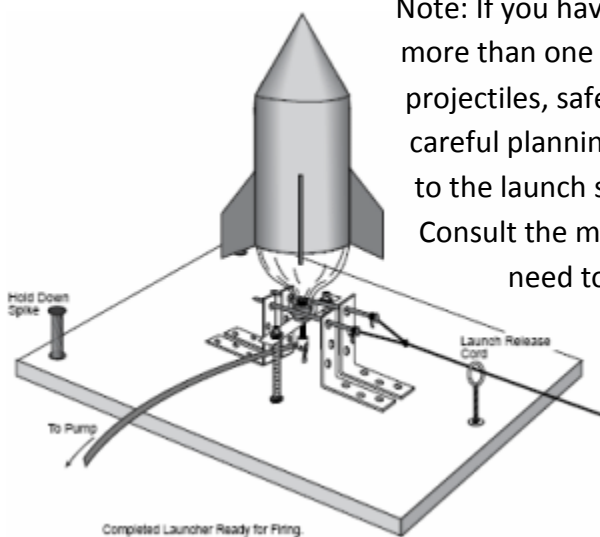

Electric drills are a common household tool. If you do not have access to one, or do not wish to drill the holes in the metal mending plate, find someone who can do the job for you.

Construction Instructions:

1. Prepare the rubber stopper by enlarging the hole with a drill. Grip the stopper lightly with a vice and gently enlarge the hole with a 3/8 inch bit and electric drill.

The rubber will stretch during cutting, making the finished hole somewhat less than 3/8 inches.

2. Remove the stopper from the vice and push the needle valve end of the tire stem through the stopper from the narrow end to the wide end.

3. Prepare the mounting plate by drilling a 3/8 inch hole through the center of the plate. Hold the plate with a vice during drilling and put on eye protection.

Enlarge the holes at the opposite ends of the plates, using a drill bit slightly larger than the holes to do this. The holes must be large enough to pass the carriage bolts through them.

(See Attachment of Mending Plate and Stopper diagram below.)

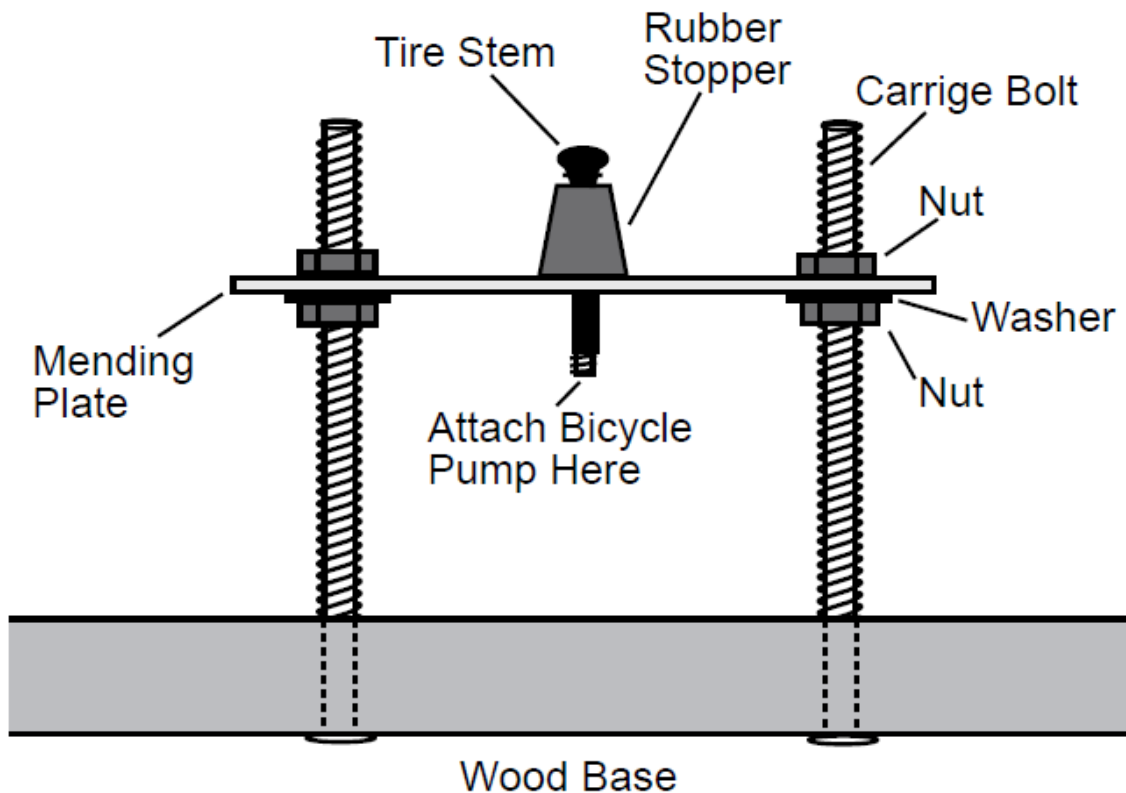

Attachment of Mending Plate and Stopper

4. Lay the mending plate in the center of the wood base and mark the centers of the two outside holes that you enlarged. Drill holes through the wood big enough to pass the carriage bolts through.
5. Push and twist the tire stem into the hole you drilled in the center of the mounting plate. The fat end of the stopper should rest on the plate.
6. Insert the carriage bolts through the wood base from the bottom up. Place a hex nut over each bolt and tighten the nut so that the bolt head pulls into the wood.
7. Screw a second nut over each bolt and spin it about half way down the bolt. Place a washer over each nut and then slip the mounting plate over the two bolts.
8. Press the neck of a 2-liter plastic bottle over the stopper. You will be using the bottle's wide neck lip for measuring in the next step.

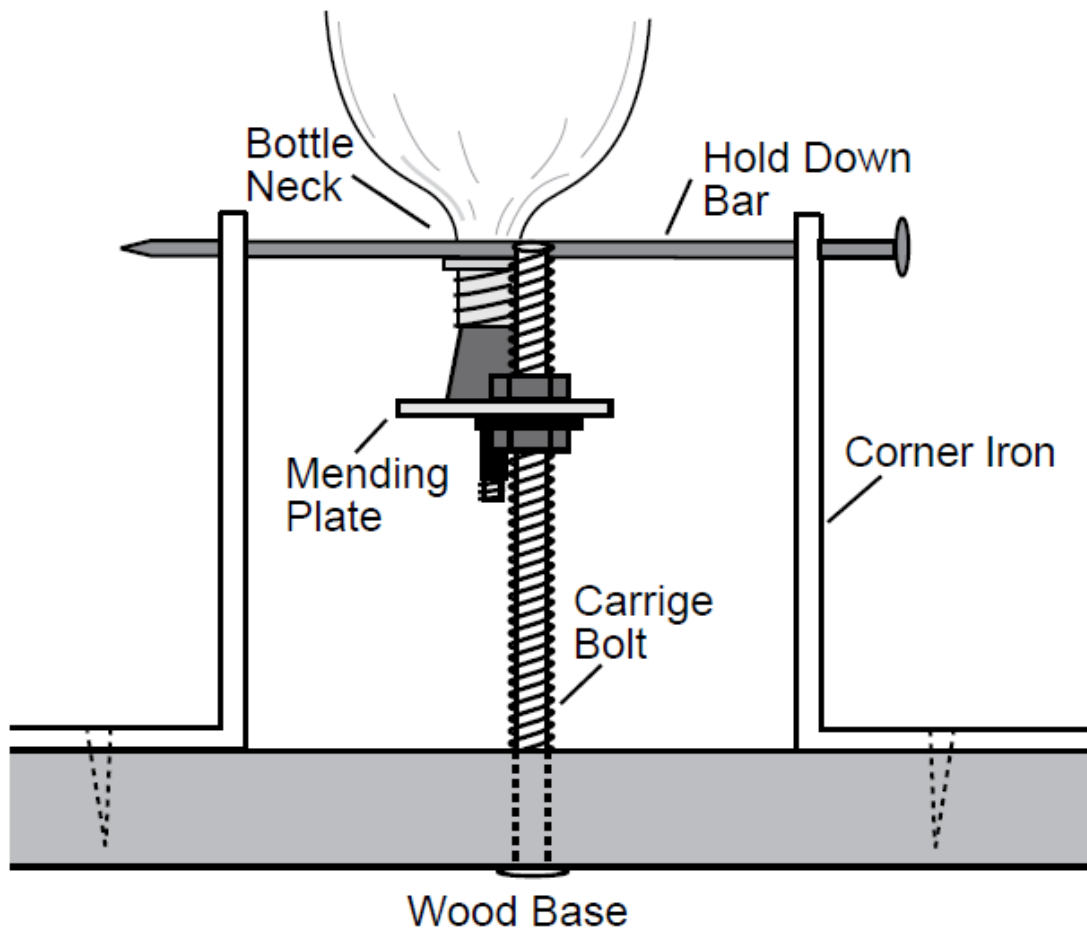

Positioning Corner Irons

9. Set up two corner irons so they look like book ends. Insert a spike through the top hole of each iron. Slide the irons near the bottle neck so that the spike rests immediately above the wide neck lip. The spike will hold the bottle in place while you pump up the rocket. If the bottle is too low, adjust the nuts beneath the mounting plate on both sides to raise it.

10. Set up the other two corner irons as you did in the previous step. Place them on the opposite side of the bottle. When you have the irons aligned so that the spikes rest above and hold the bottle lip, mark the centers of the holes on the wood base. For more precise screwing, drill small pilot holes for each screw and then screw the corner irons tightly to the base.
11. Install an eyebolt to the edge of the opposite holes for the hold down spikes. Drill a hole and hold the bolt in place with washers and nuts on top and bottom.
12. Attach the launch "pull cord" to the head end of each spike. Run the cord through the eyebolt.
13. Make final adjustments to the launcher by attaching the pump to the tire stem and pumping up the bottle. Refer to the launching instructions for safety notes. If the air seeps out around the stopper, the stopper is too loose. Use a pair of pliers or a wrench to raise each side of the mounting plate in turn to press the stopper with slightly more force to the bottle neck. When satisfied with the position, thread the remaining hex nuts over the mounting plate and tighten them to hold the plate in position.
14. Drill two holes through the wood base along one side. The holes should be large enough to pass large spikes of metal tent stakes. When the launch pad is set up on a grassy field, the stakes will hold the launcher in place when you yank the pull cord. The launcher is now complete.

Launch Safety Instructions:

1. Select a grassy field that measures approximately 30 meters across. Place the launcher in the center of the field and anchor it in place with the spikes or tent stakes. (If it is a windy day, place the launcher closer to the side of the field from which the wind is coming so that the rocket will drift on to the field as it comes down.)
2. Have each student or student group set up their rocket on the launch pad. Other students should stand back several meters. It will be easier to keep observers away by roping off the launch site.
3. After the rocket is attached to the launcher, the student pumping the rocket should put on eye protection. The rocket should be pumped no higher than about 50 pounds of pressure per square inch.
4. When pressurization is complete, all students should stand in back of the rope for the countdown.
5. Before conducting the countdown, be sure the place where the rocket is expected to come down is clear of people. Launch the rocket when the recovery range is clear.
6. Only permit the students launching the rocket to retrieve it.



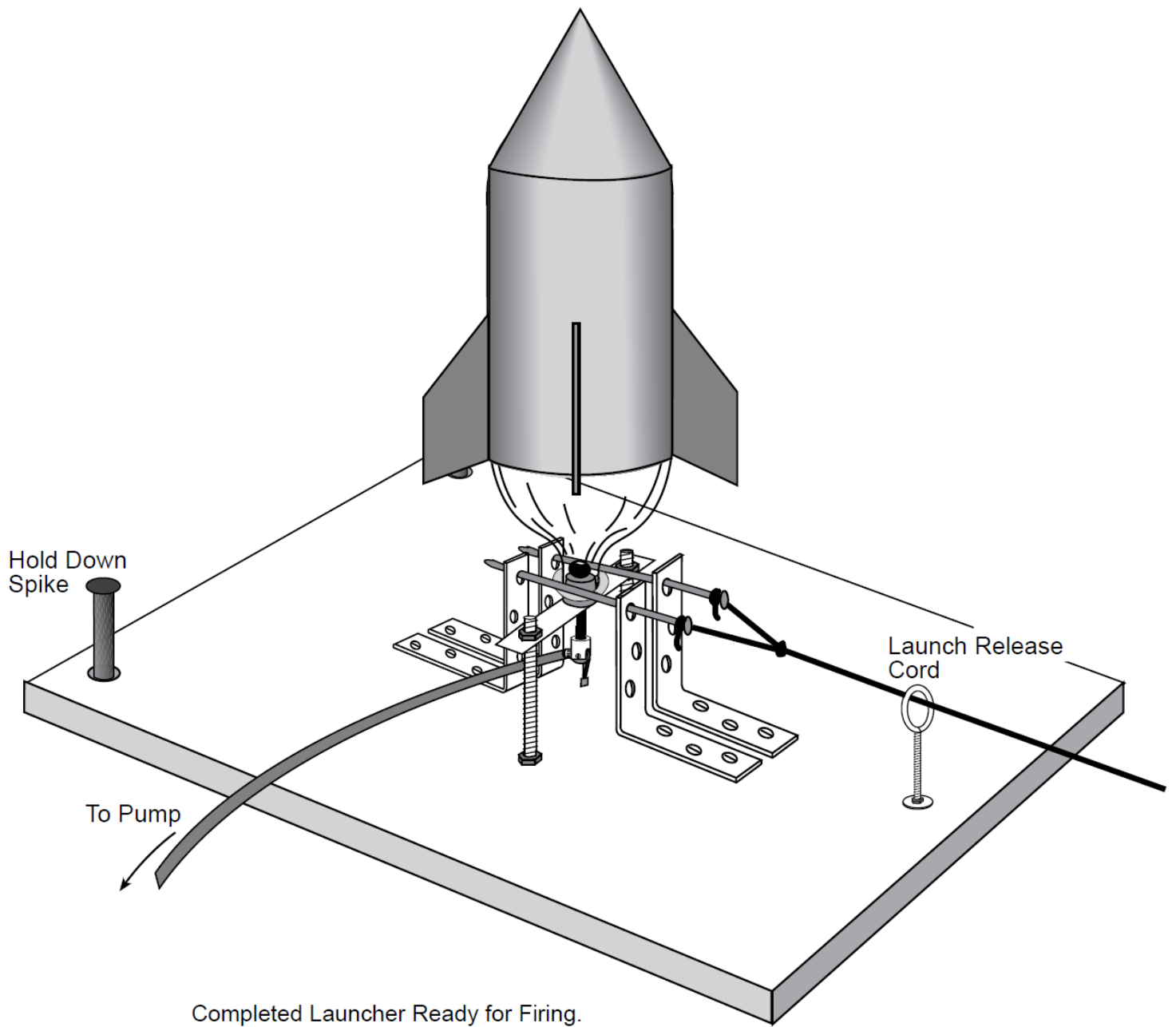

Samples of Sources and Resources

<http://kotaku.com/5742457/the-ancient-greek-hero-who-invented-the-steam-engine-cybernetics-and-vending-machines>

<http://sci-toys.com/scitoys/scitoys/thermo/thermo.html>

<http://www.ellenjmchenry.com/homeschool-freedownloads/energymachines-games/documents/BalancingBirdToyPatternPage.pdf>

<http://www.stevespanglerscience.com/geyser-rocket-car.html>

<https://www.beamazing.com/Admin/Editor/assets/Product%20Instructions/3825-SodaGeyserCar.pdf>

<http://www.jpl.nasa.gov/education/images/pdf/sodastrawrocket.pdf>

[http://www.tiki-toki.com/timeline/entry/90841/A-Brief-History-of-Rockets-and-Space-Travel#vars!date=1255-09-14 15:05:26!](http://www.tiki-toki.com/timeline/entry/90841/A-Brief-History-of-Rockets-and-Space-Travel#vars!date=1255-09-14%2015:05:26!)

<http://www.scienceoffcenter.org/science/162-balloon-rockets>

Any images, quotes, or artworks are copyrighted creations of their respective creators, authors, and owners, all rights are reserved. All images are used to explain editorial points and all content is compiled for non-profit educational use only and no claim to ownership of artwork, photographs, or source contents is made.